



FULL LINK
Smart Technology

**Smart Home | Smart Curtain
Smart Door Control | Project Development**

SMART HOME / SMART WINDOW TREATMENTS / SMART DOOR CONTROL SYSTEM / PROJECT DEVELOPMENT



FULL LINK
Smart Technology

About Us

Fulllink Smart Technology, formerly known as Bintronic Enterprise, has been devoted to the research, development, production, sales, and servicing of smart-integrated products since our establishment in 1989. With the rapid expansion of the smart applications market in homes, offices, and various other spaces, the demand for our products, including smart curtains, smart door control systems, and smart home integration and planning, continues to rise, positioning Fulllink Smart Technology as a leading and trusted smart integrated brand in the market.

Our company is well-known for continually developing high-tech products to meet market demands, with practical applications in over 200 cross-domain occasions, such as hotels, restaurants, offices, showrooms, and more. Notable flagship clients, including TSMC, Taoyuan International Airport, the "Burj Al Arab" six-star Dubai yacht hotel, BMW flagship showrooms, and the "Q Burger headquarters," a renowned Taiwanese breakfast chain store, are among those who have benefited from our solutions.

We prioritize the enhancement of product quality and technological advancements at Fulllink Smart Technology. This commitment is reflected in our acquisition of the ISO 9001 international certification and the accumulation of 38 research and development patents in Europe and Asia. Moreover, our consistent success in winning eight consecutive Taiwan Excellence Awards over four years underscores our unwavering dedication to quality improvement. Fulllink Smart Technology continues to upgrade products and conduct innovative research and development, aiming to be recognized as the "most connected and integrated smart brand."

Since 2018, Fulllink Smart Technology has initiated plans for digital transformation to expand into the global market, leading to the establishment of a brand marketing team. From the ground up, we have gradually developed a comprehensive digital marketing management system. As a result of these efforts, we have experienced sustained and stable growth in overseas markets, achieving successful sales in over 30 countries worldwide.

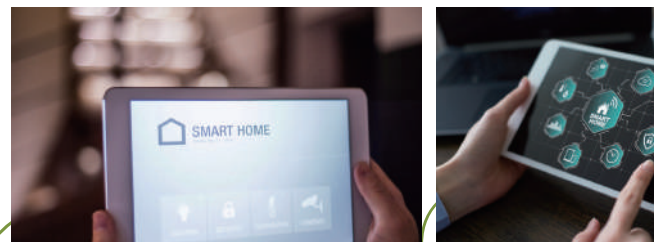

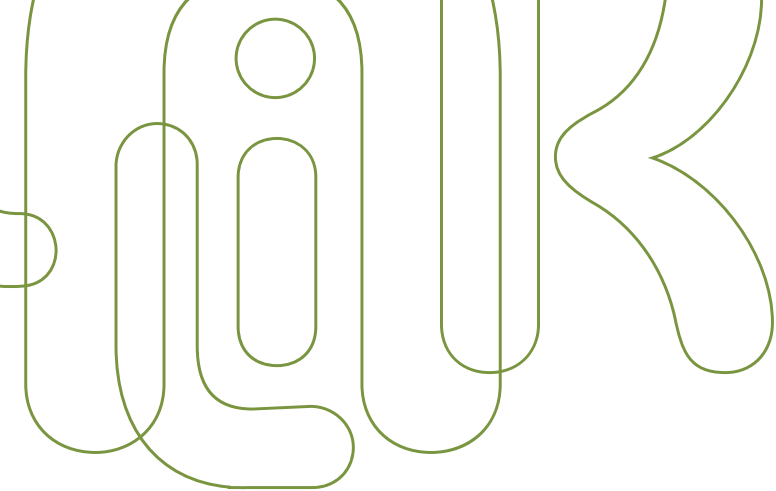

Service Items

SMART HOME

SMART WINDOW TREATMENTS

PROJECT DEVELOPMENT

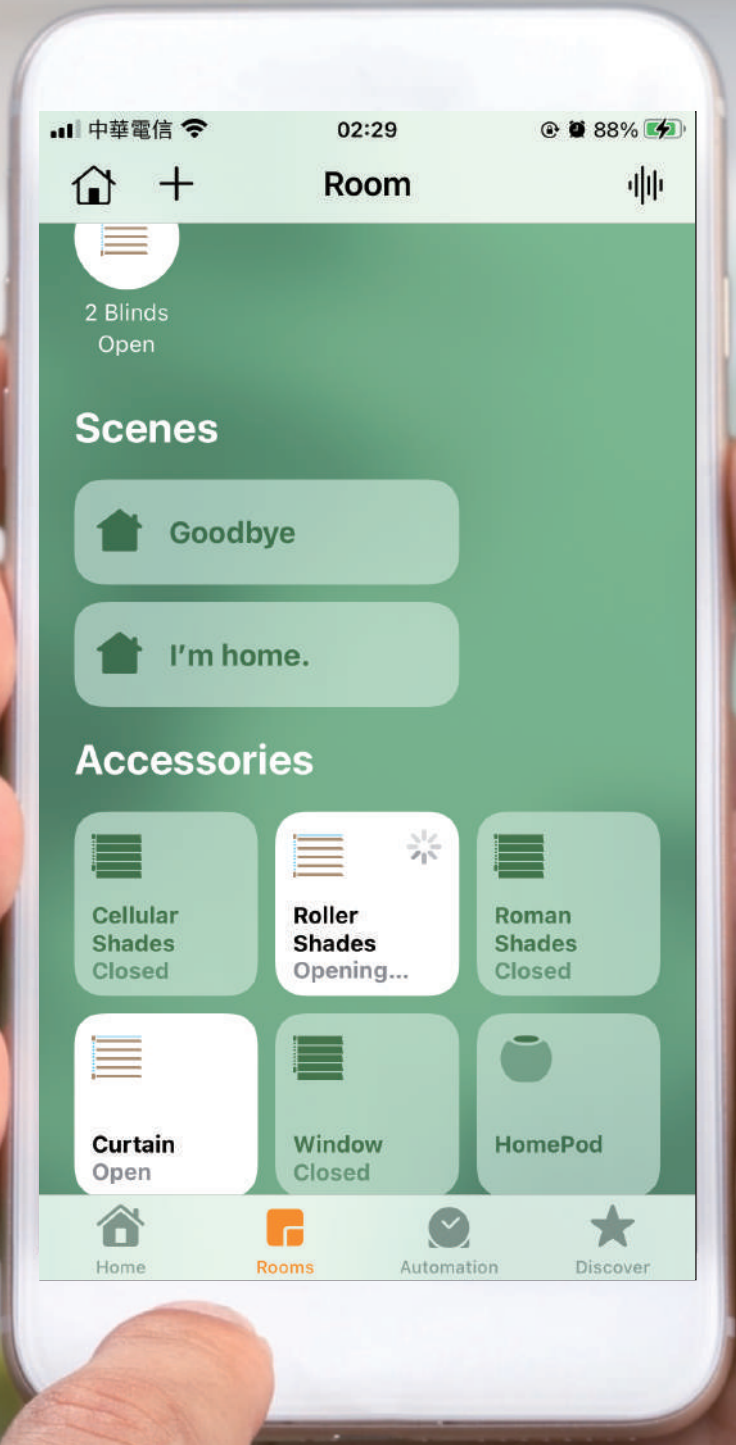

中華電信

02:29

88%



Room



2 Blinds
Open

Scenes



Goodbye



I'm home.

Accessories



Cellular
Shades
Closed



Roller
Shades
Opening...



Roman
Shades
Closed



Curtain
Open



Window
Closed



HomePod



Home



Rooms



Automation



Discover

Smart Curtain Control Modules



BT-HOMEKIT

Apple HomeKit Control Modules (Percentage Type)

Works with iPhones and iPads.



BT-620A

Google Home Control Modules (Percentage Type)

Works with Android and
iOS/iPadOS.



BT-621A

Google Home Control Modules (Standard Type)

Works with Android and
iOS/iPadOS.

Fulllink Smart Curtain Control Modules |

Regular motorized curtains rely on remote controls. Fulllink Smart Curtains offer two major platform modules, Apple HomeKit and Google Home modules. These modules can be used with the Fulllink percentage type curtain motors, providing comfortable and convenient lifestyle!

Percentage Control Curtain Motors |

What is percentage control curtain motor? The Fulllink R&D team uses programming to precisely divide the curtain's movement into one hundred segments. No longer confined to fully open or closed, set position from 0% to 100%, you can effortlessly adjust the curtain to your desired position!

Smart Control, Precise Positioning |

Curtains can be controlled by smartphones, tablets or voice. Just a call to Siri, Google Assistant, you can easily control the curtains. The screen shows the exact position percentage of each curtain in real-time, making it easy to track without getting overwhelmed by multiple curtains.

Apple HomeKit & Google Home |

Fulllink's certified smart curtain module seamlessly integrates with Apple HomeKit and Google Home systems. Able to set up with other compatible smart home products for "One-Touch Scenes" and "Scheduled Automation."

Smart Door Control Module



BT-621AD
Google Home
Smart Door Control Module

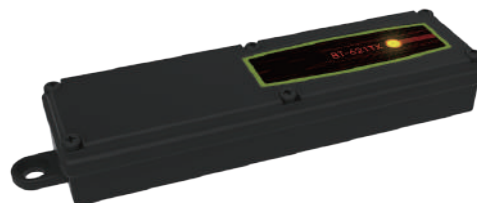

BT-621AD
Google Home
Smart Door Sensor Module

Fullink Smart Door Control Module |

Regular door controls rely on remote controls. Fullink offers Google Home smart control modules, seamlessly integrating with Fullink door control products for easy indoor and outdoor access.

Smart Door Control |

Easily control garage and community gates with your phone, tablet, or voice commands. A simple call to your Google Assistant allows effortless control, and drivers in their cars can remotely open the door with Android Auto.

Google Home |

Fullink's smart door control module seamlessly integrates with the Google Home system. Certified by Google, it can set up scenario functions with other smart home products.

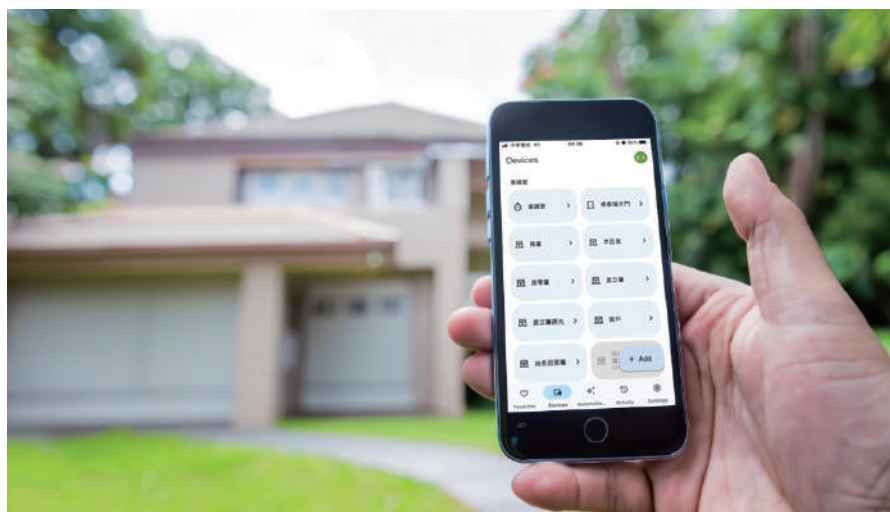

BT - RS485

RS485 Module

Global Standards, High Compatibility



Product Features

- Smart building applications : curtains, lighting, door control, all Applicable.
- Control multiple devices : A network can contain up to 63 modules. The system is connected with internet. The control can be extended to multiple curtains by gateway.
- Modbus Protocol : Adopting industrial communication protocols, easily connect to common graphic and environmental control systems, including Honeywell, Fibaro, Crestron, Lutron, PcVue, and more.
- Besides Smart Roller Shades, our TDBU Shades, Cellular Shades, Vertical Blinds... and more, can all be effortlessly controlled.

BT-RS485 Connection |

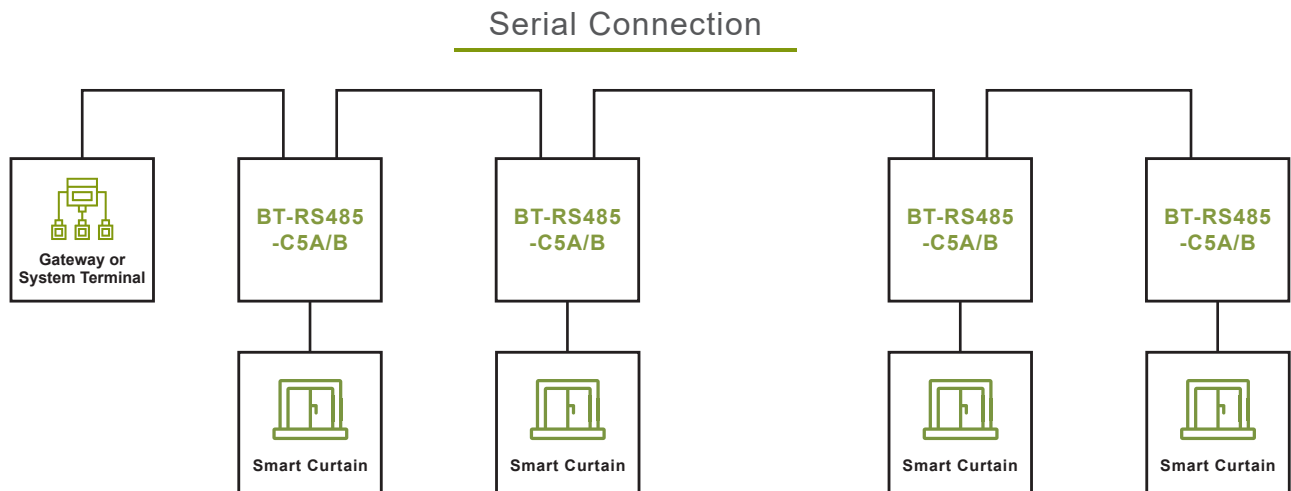

Product Features |



High Compatibility

Meets global standards, offering practical solutions for smart and low-carbon buildings. Integrates smart curtains, lighting, and door control for efficient, cost-saving operations. Able to control TDBU shades, cellular shades, and more.



Compact Size

With only 70*50*15 mm, small size and lightweight. Installation won't affect building structure and space.



Cost Saving

Price competitiveness, affordable for smart building and factory construction.



Stable Connection and Percentage Control

Peer to peer wired connection ensure stability. Using RS 485 with Fullink's curtain motors, easily adjust curtains from 0% to 100%.

Applicability |

Residential and commercial buildings' smart curtain, lighting and door control.

BT-080

AI Voice Control System

The Safest AI Voice Control



Product Features |

Easily customize your smart home assistant with Fulllink's powerful AI voice control system. It excels in voice recognition, operates without internet dependency, and effortlessly manages garage doors, community gates, and motorized curtains.

Traditional smart home control systems often raise privacy concerns. Fulllink's AI voice control system doesn't rely on cloud integration, prioritizing user privacy with 100% data security protection.



Sensitive Recognition

High recognition and noise resistance



Simple Operation

Easily control garage door, curtain



Security

User privacy assured



Easy setup without the need for internet

Simple operation, suitable for users of all ages. No need to worry about network issues, no required connection to WIFI or Bluetooth.



High recognition and noise resistance

Advanced AI voice sensor with integrated noise-resistant microphone algorithm. Powered by a high-performance processor, leading global voice recognition capabilities.



Stable and reliable offline access

No need internet connection, protect data security and respond in 2 seconds.



Just plug in, easy to use

Compatible with various devices with USB-A.



Fullink Smart Home Project

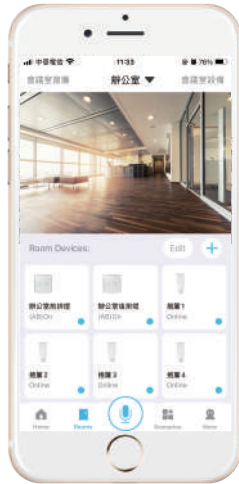

Fast and Safe Installation

Easily to install and no effect on structure



Real-time Feed Back

Connect with security sensor, product your resident



Control While Watching

Real-time observation, control situation

Product Features



Home Care

To product elderly people, children or pets, you could monitor the status of resident with simple operation.



Voice Control

Control lights, curtains, and appliances with a voice command for ultimate comfort and convenience.



Control While Watching

Monitor and control your smart devices from anywhere in the world.



Home Safety

Security alarm system activates automatically, enabling 'Away Mode' when you leave for work. Monitor home safety anytime

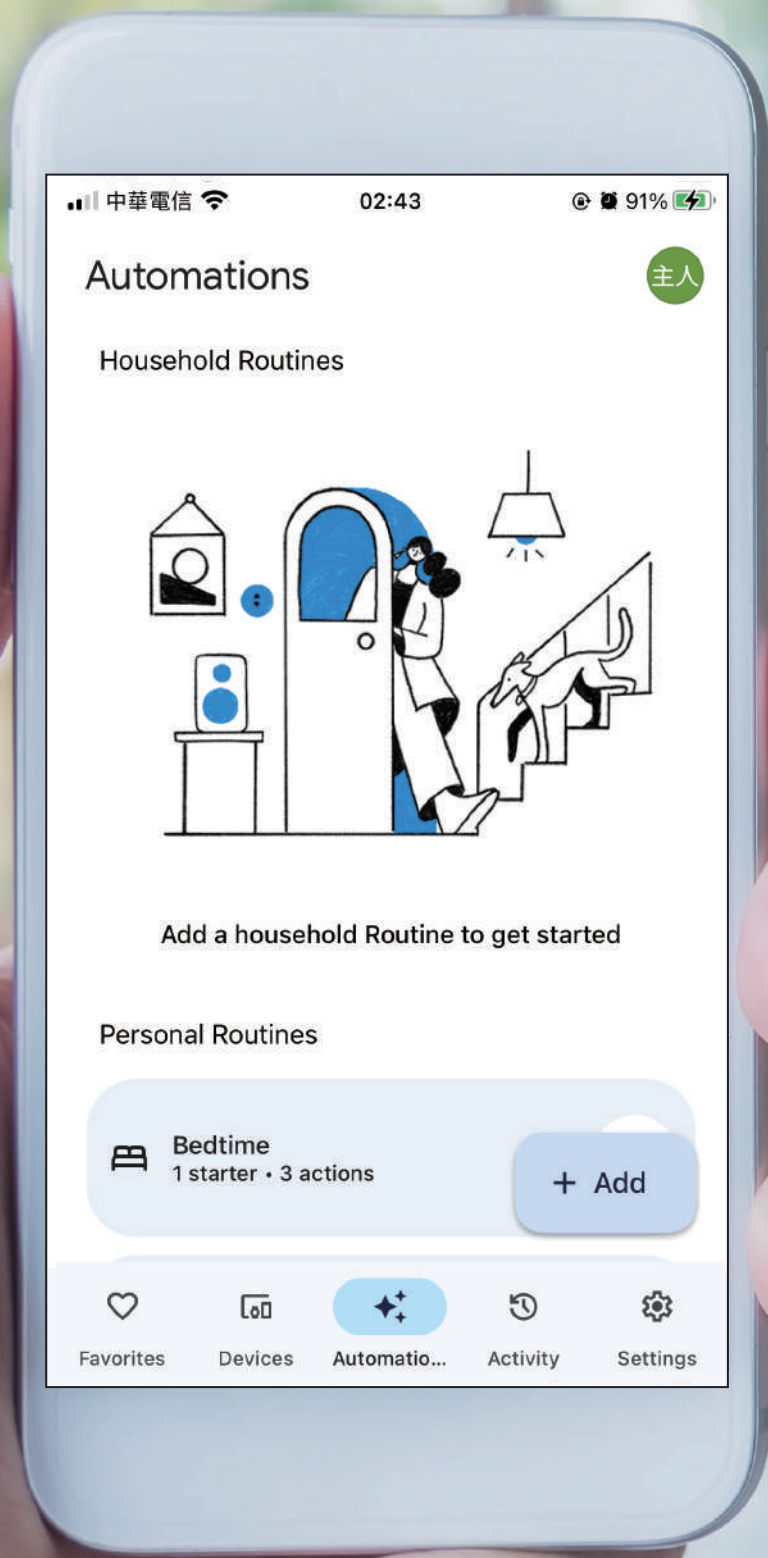

中華電信 02:43 91%

Automations 主人

Household Routines



Add a household Routine to get started

Personal Routines

 **Bedtime**
1 starter • 3 actions + Add

-  Favorites
-  Devices
-  Automatio...
-  Activity
-  Settings

BT-BCK

Smart Drapes - Belt Driven

Exquisite smart curtains with humanized design.



Product Features |

- Special elastic-free belt transmission with good durability.
- Fast, quiet, and can be switched to manual operation during power failures.
- If obstructed, the special protectin design is able to stop the motor immediately to ensure safety.
- Patented unpowered clutch with high transmission efficiency.
- Robust and durable as the continuous test for reliability had been conducted for 50,000 times.
- Two ways (one-way/central) to open or close the curtain, with an extra-long track which can be transported in two separat sections.
- Obtained the CE, FCC and the NCC certifications in multiple nations. The quality is reliable.
- Can be applied with different control systems. It is compatible with Apple HomeKit and Google Home system which owns high compatibility and expandability.

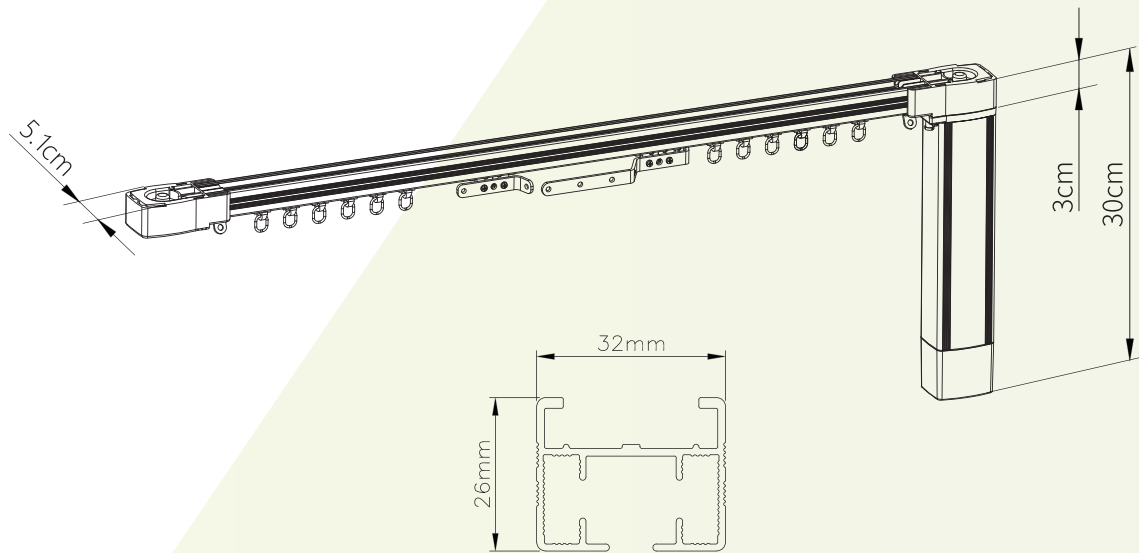

Specification

Operating Voltage	DC 24V 0.8A	Manual Override Distance	10 CM
Rated Voltage	Built-in Power Supply 110V-240V	Frequency	433.92 MHz, ASK
Rated Power	16.5 W	Range of Remote Control	30 M
Standby Power	0.85 W	Max. Curtain Weight.	50KG within 6M
Safety Curtain Weight	50 KG	(without curves)	45KG within 6M-8M
Max. Single Point Hoisting	1.2 KG		40KG within 8M-10M
Open/Close Speed	12 CM/sec		35KG within 10M-12M
Rated Torque	1.0 Nm	Noise Level	40.5 db



BT-MRS

Smart Roller Shades - DC Tubular Motors

The smart curtains with beautiful and simplicity design that can be scrolled up and down.



Product Features |

- Low voltage and low power consumption DC motor to be safe and energy-saving.
- Precise electronic positioning to set the height by your will. It is convenient and reliable.
- Multi-window operations can be precisely and uniformly positioned.
- Startup and close down with an elegant pace.
- Anti-tangling protection that is smart and safe.
- Low noise with highly precise transmission. It is quiet and reliable.
- Robust and durable as the continuous operation test for reliability had been conducted for 60,000 times
- Obtained the CE, FCC and NCC certifications in multiple nations. The quality is reliable.
- Can be applied with different control systems. It is compatible with Apple HomeKit and Google Home system which owns high compatibility and expandability.
- Additional types using tubular motors: Smart Zebra Shades and Smart Sheer Horizontal Blinds.

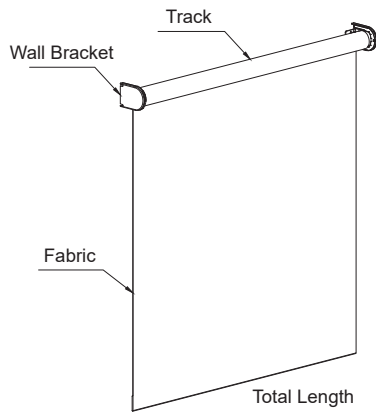

2mm (Thickness of Bracket Cover)

2mm (Thickness of Bracket Cover)

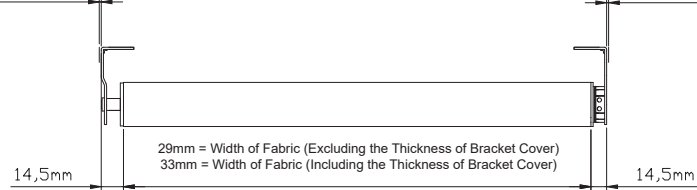

25

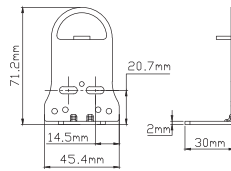
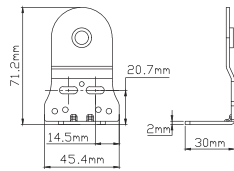

Idler Bracket Drive Bracket

50

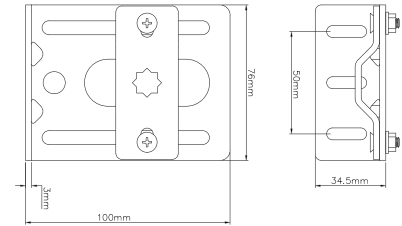

25mm Spec

Motor's Outer Diameter	Ø 25 mm	Range of Remote Control	30 M
Outer Tube's Diameter	Ø 40 mm	Rated Voltage	Built-in Power Supply AC100V-240V
Operating Voltage	DC 12V	Max. Rated Current	1.5 A
Frequency	433.92 MHz, ASK	Max. Rated Power	8.4 W
Rotation Speed	30 rpm	Standby Power	0.25 W
Torque	1.1 Nm	Degree of Protection	IP 44
Max. Size	W 2.4 M x H 3.2 M	Noise Level	39 db

Note: The motor is equipped with dry contacts for direct operation.

50 mm Spec

Motor's Outer Diameter	Ø 45 mm	Max. Rated Current	0.8 A
Outer Tube's Diameter	Ø 55 mm - 300 cm Ø 70 mm - 360 cm	Max. Rated Power	14 W
Operating Voltage	DC 24V	Standby Power	1.65 W
Frequency	433.92 MHz, ASK	Degree of Protection	IP44
Rotation Speed	13 rpm	Noise Level	38 db
Torque	4 Nm	Range of Remote Control	30 M
Max. Size	W 3 M X H 3.5 M	Load Capacity	Ø 55mm-12kg Ø 70mm-10kg
Min. Size	W 70 cm	Rated Voltage	Built-in Power Supply AC100V-240V

BT-MZS

Smart Zebra Shades

The smart curtains that display soft natural light with multiple vision and interlaced beauty.



Product Features |

- One touch to automatically filter sunlight. It is smart and convenient.
- Smart light filtering design for soft and precise light filtering.
- Low voltage and low power consumption DC motor to be safe and energy-saving.
- Precise electronic positioning to set the height by your will. It is convenient and reliable.
- Startup and close down with an elegant pace.
- Anti-tangling protection that is smart and safe.
- Low noise with high precision transmission. It is quiet and reliable.
- Robust and durable as the continuous operation test for reliability had been conducted for 60,000 times.
- Obtained the CE, FCC and NCC certifications in multiple nations. The quality is reliable.
- Can be applied with different control systems. It is compatible with Apple HomeKit and Google Home system which owns high compatibility and expandability.



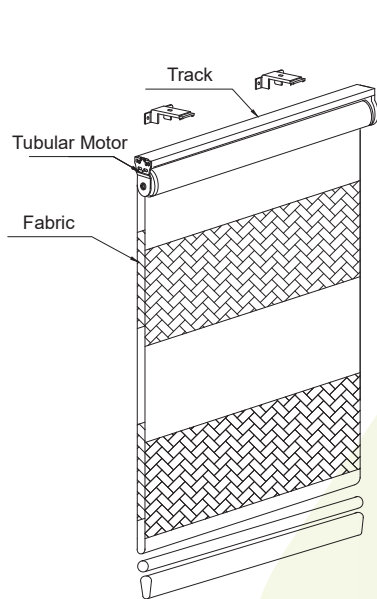

2mm (Thickness of Bracket Cover)

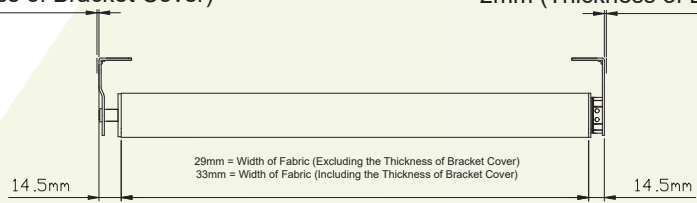

2mm (Thickness of Bracket Cover)

Idler Bracket

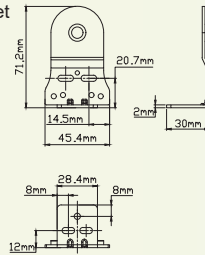

Drive Bracket

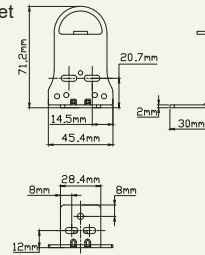

Specification

Operating Voltage	DC 12V	Torque	1.1 Nm
Frequency	433.92 MHz, ASK	Max. Size	W 2.4 M x H 3.2 M
Load Capacity	4.5 KG	Range of Remote Control	30 M
Rotation Speed	30 rpm	Rated Voltage	Built-in Power Supply AC100V-240V



BT-SHB

Smart Sheer Horizontal Blinds

The best choice for both privacy and light filtering.



Product Features |

- One touch to automatically filter sunlight. It is smart and convenient.
- Smart light filtering design for soft and precise light filtering.
- Low voltage and low power consumption DC motor to be safe and energy-saving.
- Precise electronic positioning to set the height by your will. It is convenient and reliable.
- Startup and close down with an elegant pace.
- Anti-tangling protection that is smart and safe.
- Low noise with high precision transmission. It is quiet and reliable.
- Robust and durable as the continuous operation test for reliability had been conducted for 60,000 times.
- Obtained the CE, FCC and NCC certifications in multiple nations. The quality is reliable.
- Can be applied with different control systems. It is compatible with Google Home system which owns high compatibility and expandability.



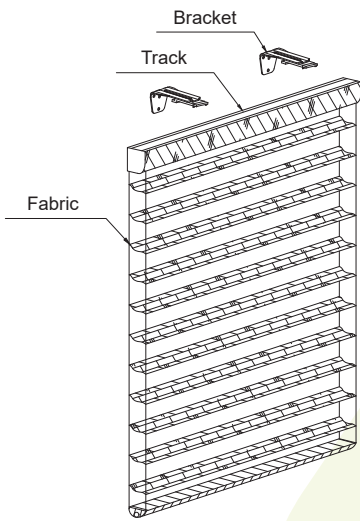

2mm (Thickness of Bracket Cover)

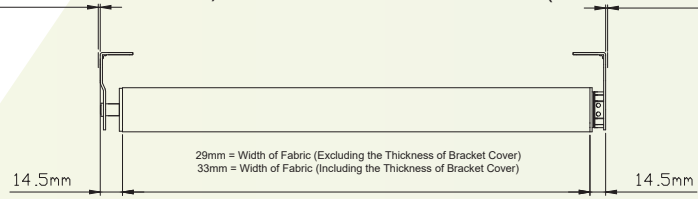

2mm (Thickness of Bracket Cover)

Idler Bracket

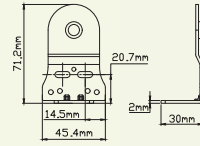

Drive Bracket

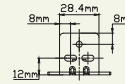
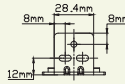
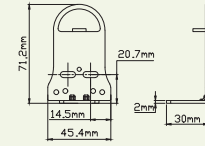

Specification

Operating Voltage	DC 12V	Torque	1.1 Nm
Frequency	433.92 MHz, ASK	Max. Size	W 2.4 M x H 3.2 M
Load Capacity	4.5 KG	Range of Remote Control	30 M
Rotation Speed	30 rpm	Rated Voltage	Built-in Power Supply 110V-240V



BT-MVB

Smart Vertical Blinds

Suitable for large French windows, offices, government agencies and public areas.



Product Features

- Low voltage and low power consumption DC motor to be safe and energy-saving.
- Low noise with high precision transmission. It is quiet and reliable.
- When turning the switch on or off, the slats will automatically be adjusted to the direction perpendicular to the track before the movement to avoid tangling.
- The motor and the controller are installed inside the track which makes it aesthetic.
- It adopted the screw rod transmission so that its elasticity can last forever.
- The dual safety protection device of current overload detection and total movement setting is not required.
- Two ways (one-way/central) to open or close the curtain.
- Obtained the CE, FCC and NCC certifications in multiple nations. The quality is reliable.
- Can be applied with different control systems. It is compatible with Google Home system which owns high compatibility and expandability.

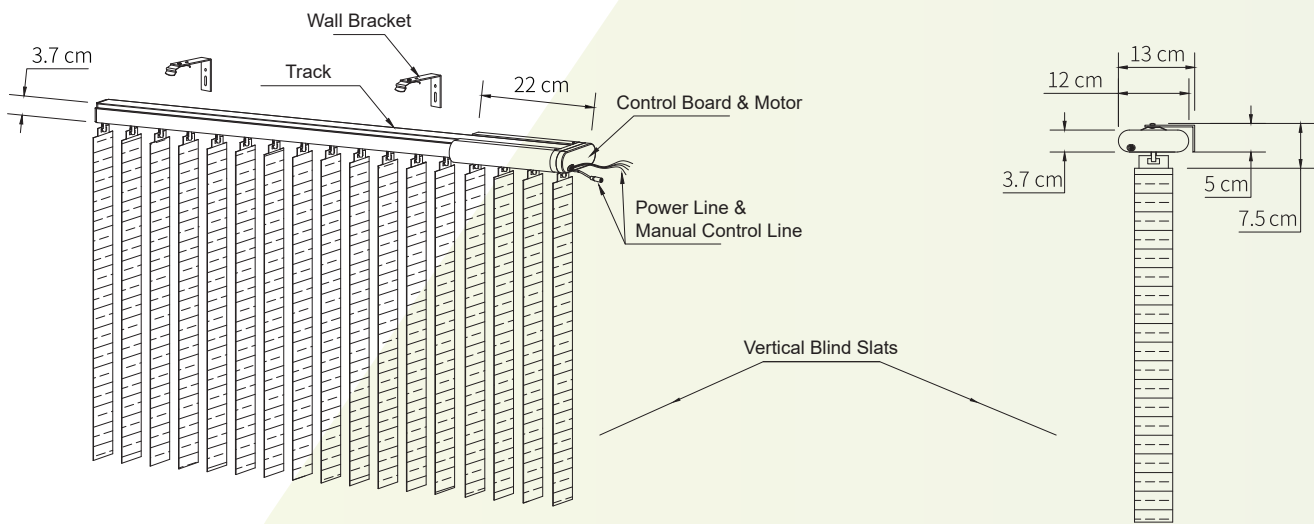

Specification

Operating Voltage	DC 24V	M1 Rotation Speed	250 rpm
Frequency	433.92 MHz, ASK	Max. Size	5.4M (maximum)
Load Capacity	0.5 kg for each carrier stem 30 kg (maximum)	Range of Remote Control	30 M
		Rated Voltage	AC 100V-240V



Additional Types | Sheer Fold Blinds
 (suitable distance piece: 7.9cm)(end H/J carrier set)
 Venetian Blinds
 (suitable distance piece: 11.5 cm)(end H carrier set)

BT-MRS

Smart Roman Shades

Innovative and flexible up and down movement for opening and closing of the smart roman shades.



Product Features |

- The patented design of the cord winder allows fabric to be rolled and unrolled simultaneously in a parallel operation, eliminating any issues with tangled wires.
- Precise electronic positioning to set the height by your will. It is convenient and reliable.
- Robust and durable as the continuous operation test for reliability had been conducted for 27,000 times.
- Obtained the CE, FCC and NCC certifications in multiple nations. The quality is reliable.
- Can be applied with different control systems. It is compatible with Apple HomeKit and Google Home system which owns high compatibility and expandability.

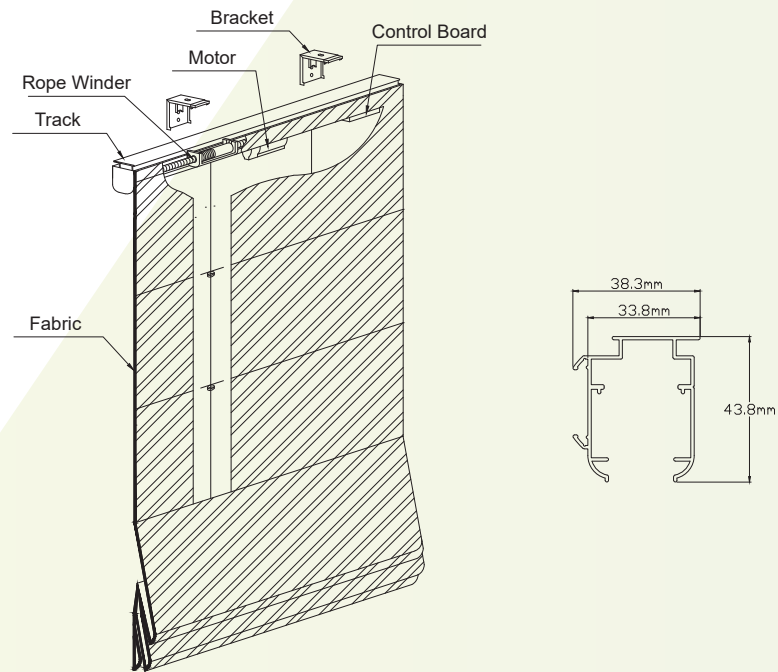

Specification

Operating Voltage	DC 24V	Torque	1 Nm
Frequency	433.92 MHz, ASK	Max. Size	W 5.4 M x H 3.5 M
Load Capacity	5 kgs/1 motor, 10 kgs/2 motors (max)	Range of Remote Control	30 M
Rotation Speed	39 rpm	Rated Voltage	AC 100V-240V



BT-MAB

Smart Aluminum Venetian Blinds

The improved motorized venetian blinds that are noble and practical.



Product Features |

- Low power DC motor that is safe and energy saving.
- The motor is silent with a precise and reliable movement control.
- Precise electronic positioning to set the height by your will. It is convenient and reliable.
- Obtained the CE, FCC and NCC certifications in multiple nations. The quality is reliable.
- Can be applied with different control systems. It is compatible with Google Home system which owns high compatibility and expandability.

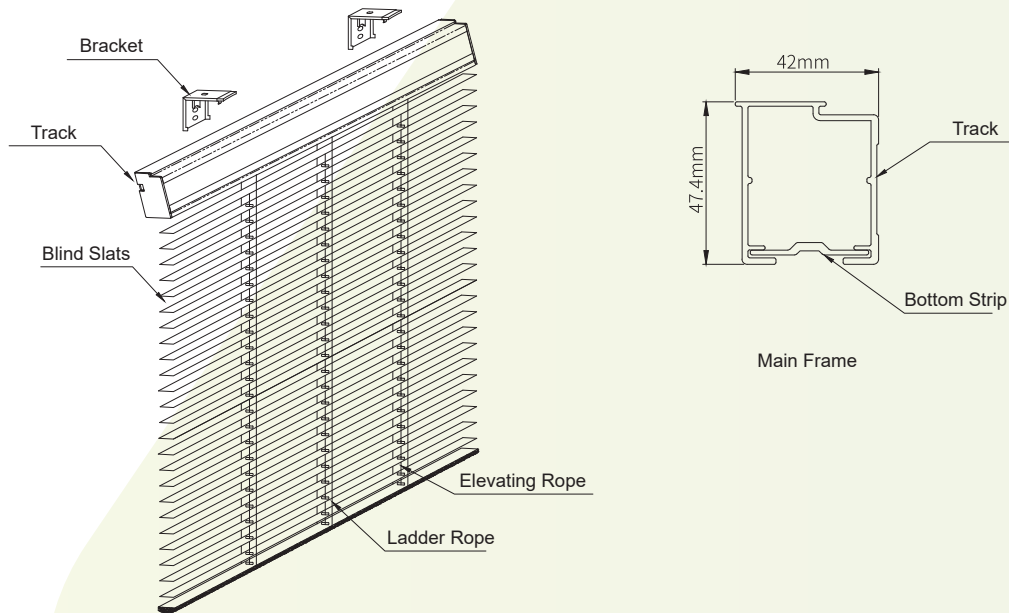

Specification

Operating Voltage	DC 24V	Max. Size	W 2.4 M x H 3.5 M
Frequency	433.92 MHz, ASK	Blind Slats' Width	25mm(slats recommended 35mm)
Load Capacity	4 KG	Left and right distance	over 20 cm
Rotation Speed	39 rpm	Range of Remote Control	30 M
Torque	1 Nm	Rated Voltage	AC 100V-240V



BT-MWB

Smart Wooden Venetian Blinds

The smart blinds with elegant style for light filtering and privacy.



Product Features |

- The humanized operating system that can remotely control the switch of the slats.
- Precise electronic positioning to set the height by your will. It is convenient and reliable.
- Obtained the CE, FCC and NCC certifications in multiple nations. The quality is reliable.
- Can be applied with different control systems. It is compatible with Apple HomeKit and Google Home system which owns high compatibility and expandability.

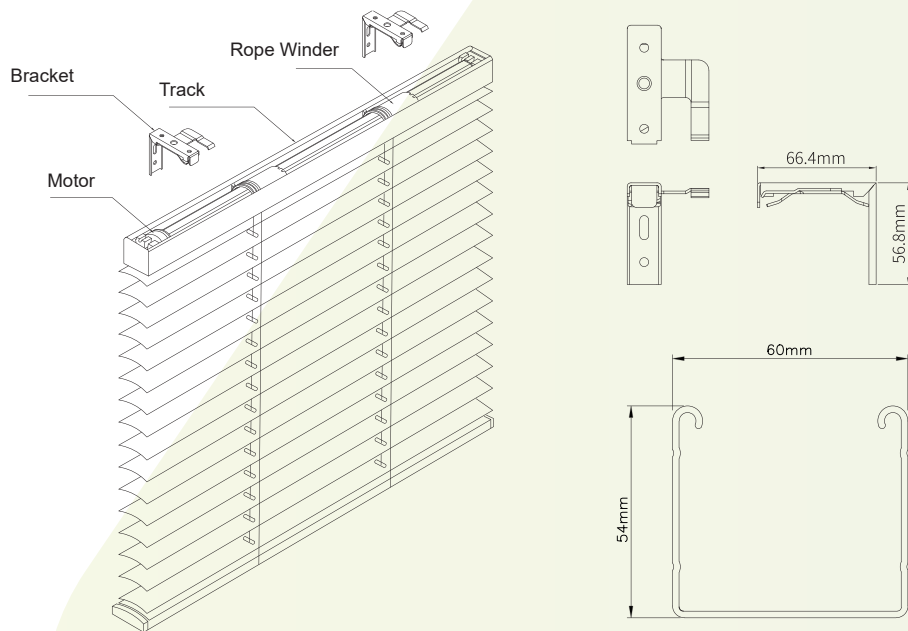

Specification

Operating Voltage	AC 110V-220V	Blind Slats' Width	35mm & 50mm
Frequency	433.92 MHz, ASK	Left and right distance	Over 15 cm
Rotation Speed	21 rpm	Range of Remote Control	30 M
Torque	8 Nm	Motor Option	AC 110V or 220V
Max. Size	W 2.4 M x H 3.5 M		



BT-MCS

Smart Cellular Shades (Standard Type)

The motorized curtains with elegance, simplicity and modern design.



Product Features |

- Low voltage and low power consumption DC motor to be safe and energy-saving.
- Precise electronic positioning to set the height by your will. It is convenient and reliable.
- Low noise with high precision transmission. It is quiet and reliable.
- Obtained the CE, FCC and NCC certifications in multiple nations. The quality is reliable.
- Can be applied with different control systems. It is compatible with Apple HomeKit and Google Home system which owns high compatibility and expandability.

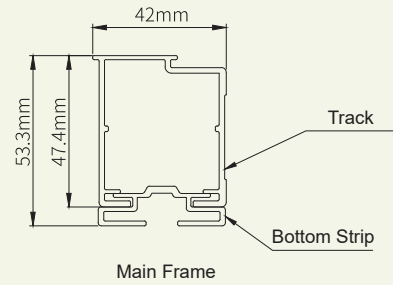
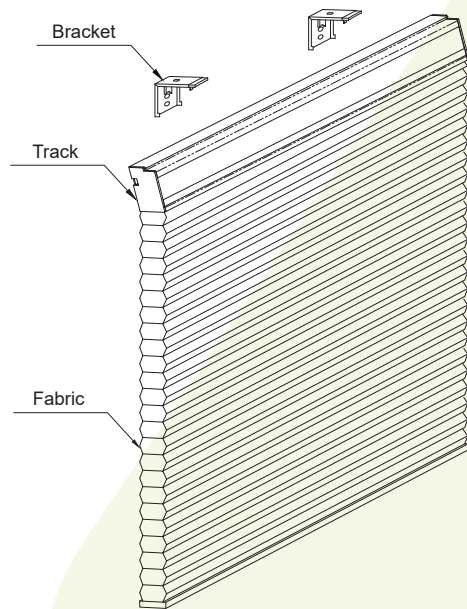

Specification

Operating Voltage	DC 24V	Max. Size	W 2.4 M x H 3.5 M
Frequency	433.92 MHz, ASK	Blind Slats' Width	25 mm or 38 mm
Load Capacity	4 KG	Left and right distance	over 20 cm
Rotation Speed	39 rpm	Range of Remote Control	30 M
Torque	1 Nm	Rated Voltage	AC 100V-240V



BT-TDBU

Smart Top-Down/ Bottom-Up Cellular Shades

Innovative and flexible up and down movement for opening and closing of the smart cellular shades.

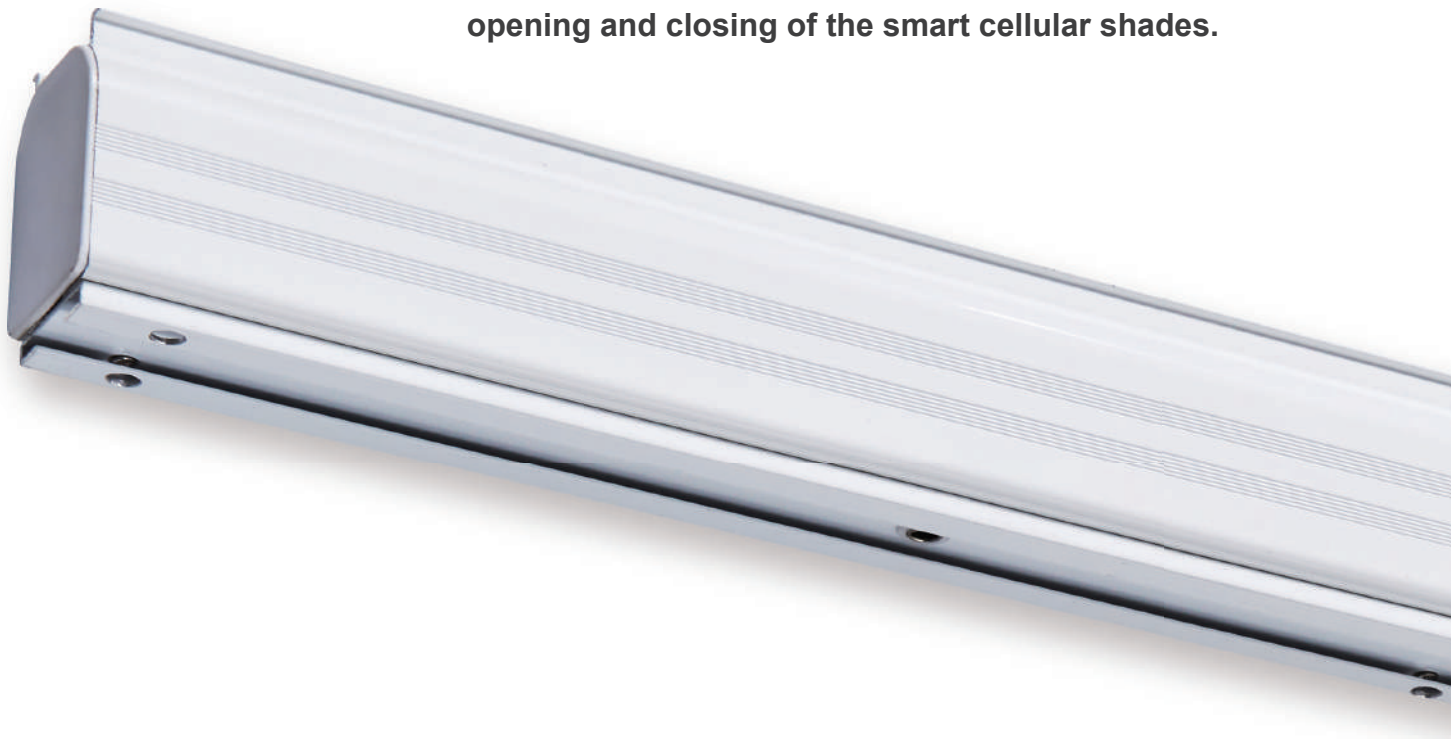

Product Features |

- Smart detection to control by your will.
- Low voltage and low power consumption DC motor to be safe and energy-saving.
- Precise electronic positioning to set the height by your will. It is convenient and reliable.
- Low noise with high precision transmission. It is quiet and reliable.
- Obtained the CE, FCC and NCC certifications in multiple nations. The quality is reliable.
- Can be applied with different control systems. It is compatible with and Google Home system which owns high compatibility and expandability.

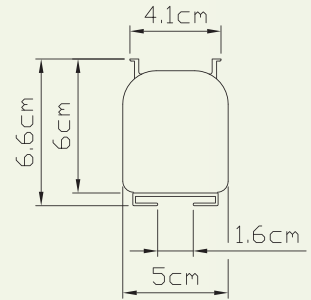

Specification

Operating Voltage	DC 24V	Max. Size	W 3.2 M x H 3.5 M (max)
Frequency	433.92 MHz, ASK		W 1 M x H 1M (min)
Load Capacity	8 KG (4KG/layer)(max)	Blind Slats' Width	38 mm & 47 mm
Rotation Speed	39 rpm	Left and Right Distance	over 20 cm
Torque	1 Nm (per layer)	Rated Voltage	AC 100V-240V
Range of Remote Control	30 M		



BT-MSB

Motorized Skylight Blinds

A comfortable selection to make the room look spacious and bright.



Product Features |

- Low voltage and low power consumption DC motor to be safe and energy-saving.
- Precise electronic positioning to set the height by your will. It is convenient and reliable.
- Low noise with high precision transmission. It is quiet and reliable.
- The two belt-type tracks and coaxial motors are adopted to control the curtain surface.
- Adopts the elastic-free track transmission, which is durable and not easy to deform or break.
- Obtained the CE, FCC and NCC certifications in multiple nations. The quality is reliable.
- Can be applied with different control systems. It is compatible with Google Home system which owns high compatibility and expandability.

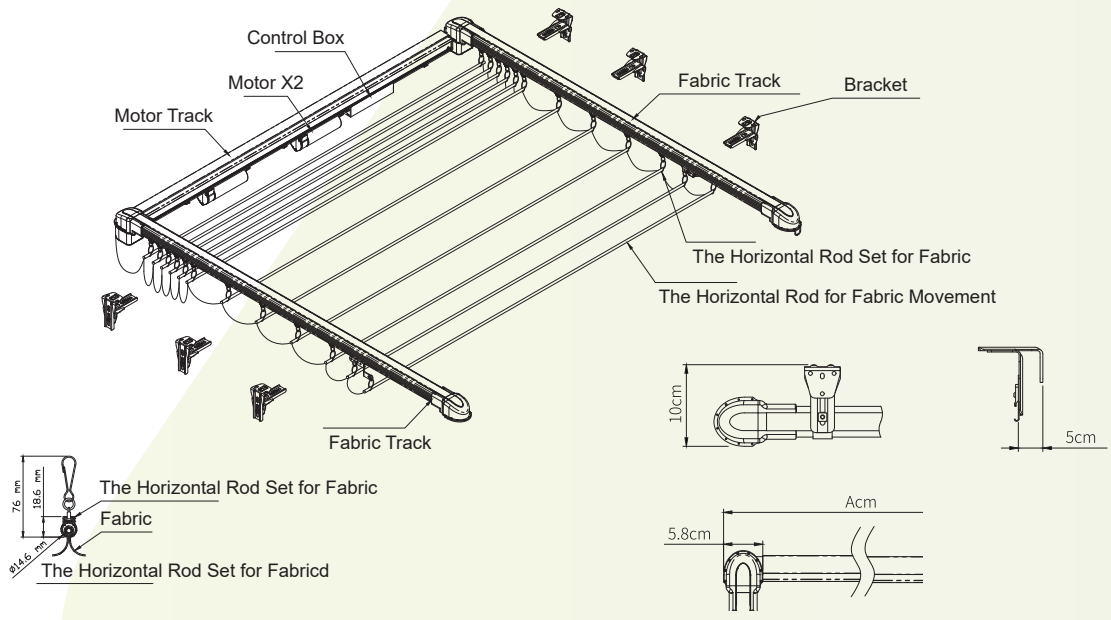

Specification

Operating Voltage	DC 24V	Torque	1 Nm
Frequency	433.92 MHz, ASK	Max. Size	Track length 3.4 M(max)
Load Capacity	30 KG	Range of Remote Control	30 M
Rotation Speed	39 rpm	Rated Voltage	AC 100V-240V



Wall Mounted Wireless Transmitters

Frequency: 433.92MHz,ASK

Battery: DC 3V(CR2032)

Applicable to all public areas and business venues.



BT-129A
Single Channel
4 Keys



BT-129A4
1 to 4
4 keys



BT-129B
1 to 2
6 Keys

BT-073

Remote Controls



Drapes



1 to 16



Roller
Shades



Percentage Control
5-Segment Type



Vertical
Blinds



TDBU
Shades



Zebra
Shades

BT-SWA

Smart Window Actuator

Space Magician for Light Filtering

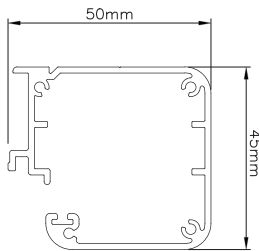

The safest actuator

When indoor carbon monoxide levels are excessively high, traditional aluminum windows without integrated smart detection systems may pose significant concerns regarding indoor air circulation. Fullink has developed the safest smart window motor system, requiring only additional pairing with a detection system. It automatically senses indoor and outdoor air quality, temperature, and humidity, adjusting window positions accordingly, ensuring greater peace of mind for indoor occupants!



Breathable

All of the smart window actuators can automatically regulate the indoor air.



Brake Mechanism

All of the smart window actuators have a safety entrapment protection mechanism.



Smart

All of the smart window actuators can be connected to the smart home system.

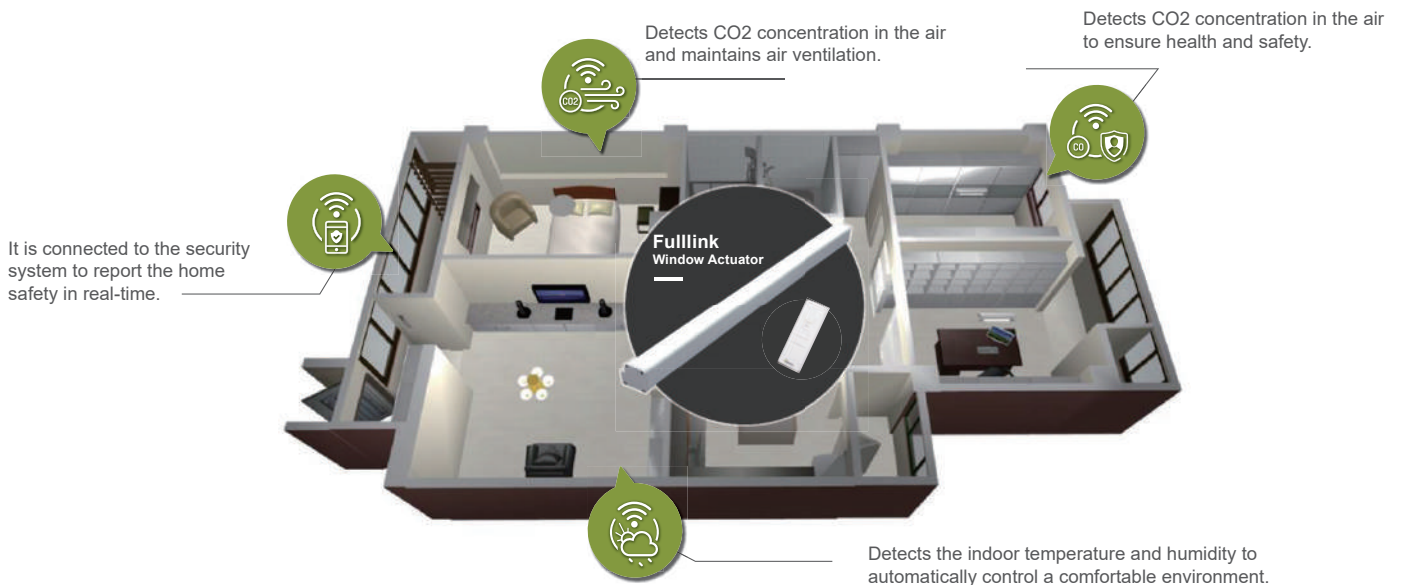

Health protection for a comfortable life

Air Detection-Detects the indoor air quality (CO, PM2.5, etc) to protect your respiratory system and health.
 Comfortable Space - Detects the indoor temperature and humidity and automatically adjusts to the optimum position for adapting to the weather changes such as rain or shine.



Smart device with one touch to control

Safety Entrapment Protection Mechanism - The operations will stop immediately when its movement is obstructed for entrapment protection.
 Manual Switch - It can be switched to the manual mode during power failures.



Smart and value-added device for safe environment

Check at Any Time - Users can check the status and control the smart window actuator at any time through a smart phone.
 Safety Mechanism - The security system will be triggered immediately when necessary, to effectively monitor the safety of the environment.



The installation is simple

Quick Installation - It does not affect the interior design and the system and device installation can be completed easily
 Safety Mechanism - The security system will be triggered immediately when necessary, to effectively monitor the safety of the environment.

Specification

Operating Voltage	DC 24V 1A	Rated Torque	1.0 Nm
Rated Voltage	Built-in Power Supply 110V-240V	Frequency	433.92 MHz, ASK
Max. current	500 MA	Range of Remote Control	30 M
Safety Curtain Weight	30 KG	Specifications	W100CM / H140CM
Open/Close Speed	1.5CM/sec		

Option	Spec	Spec
Width	100 CM	140 CM
Max. Length	60 CM	100 CM

Link Smart.



Fulllink Smart Technology Co., Ltd.

No. 62, Bengong 5th Rd., Gangshan Dist.,
Kaohsiung City 82059 , Taiwan (R.O.C.)

T 886 7 623 6001 **F** 886 7 623 5583

Contact Us

Website



Email

